

assessment for learning

year 9

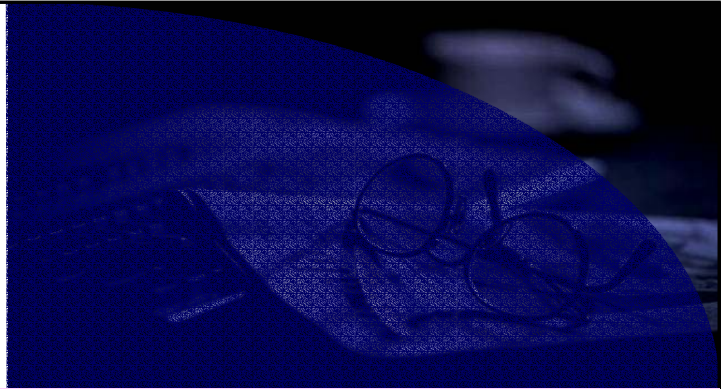

Science Interactive LTD. PO BOX 50764 LONDON NW6 9AT

web: www.science-interactive.co.uk

9L Pressure and moments

Assessment for learning...year 9 (level 3-6)

Answer all questions:

Total marks	26
Time allowed	25 mins.

Question 1:

(a) A ladder is hung on **one** hook so that it balances horizontally.

Draw an arrow on the diagram below to show the position of the hook.

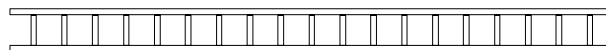

1 mark

(b) A window cleaner puts the ladder on his shoulder in the position shown.

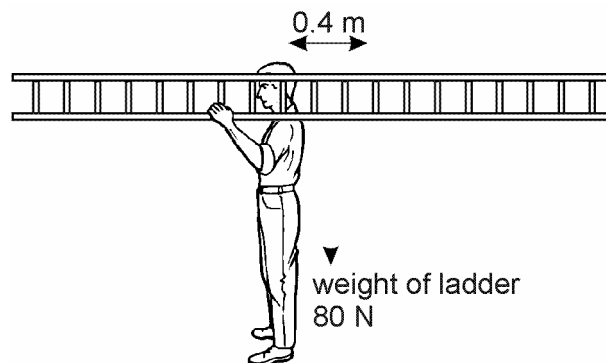

(i) The weight of the ladder acts at its centre, as shown. Calculate the turning effect, or moment, about his shoulder due to the weight of the ladder. Give the unit.

.....
.....

2 marks

The window cleaner hooks his bucket onto the ladder as shown in the diagram. The bucket weighs 15 N and is 0.8 m from his shoulder.

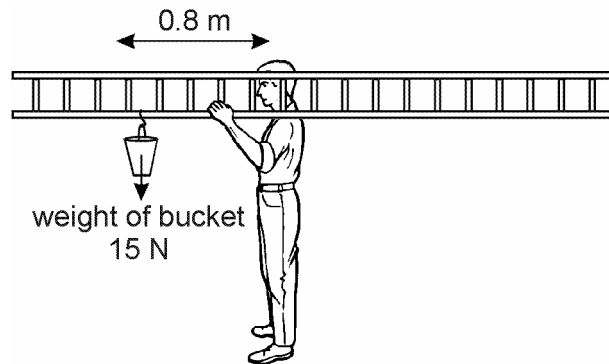

(ii) Calculate the turning effect, or moment, about his shoulder due to the weight of the bucket only.

.....
.....

1 mark

(iii) Calculate the size and direction (clockwise or anticlockwise) of the total turning effect, or moment, about his shoulder due to the weight of the ladder and the weight of the bucket.

.....
.....

1 mark

(c) To keep the ladder and bucket balanced on his shoulder, the window cleaner has to pull down with his hand.

(i) How can he move the ladder on his shoulder to reduce the force his hand has to balance?

.....
.....

1 mark

(ii) How could he change the position of the bucket to reduce the force his hand has to balance?

.....

1 mark

Maximum 7 marks

Question 2:

A drawing pin is pressed into a notice board.

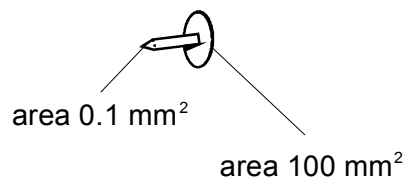

The pin is pressed into the notice board with a force of 20 N.
The head of the drawing pin has an area of 100 mm^2 .
The point of the pin has an area of 0.1 mm^2 .

(a) What is the size of the force exerted by the **point** of the pin on the notice board?

..... N

1 mark

(b) Calculate the pressure exerted by the **point** of the drawing pin.
Give the unit.

.....
.....
.....
.....

2 marks

Maximum 3 marks

Question 3:

The drawing shows a cylinder of butane. The butane is under pressure in the cylinder. Most of the butane in the cylinder is liquid, but some is a gas.

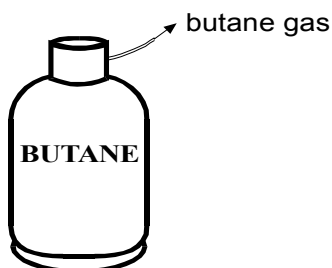

(a) Tick the **two** correct statements about the molecules of butane gas in the cylinder.

The molecules of gas are:

closer together than those in the liquid;

further apart than those in the liquid;

the same distance apart as those in the liquid;

bigger than those in the liquid;

smaller than those in the liquid;

the same size as those in the liquid;

2 marks

(b) The gas molecules exert a pressure on the inside of the cylinder. How do the moving molecules cause this pressure?

.....
.....

1 mark

(c) (i) Explain why the pressure inside the cylinder falls when the temperature falls.

.....
.....
.....
.....

2 marks

(ii) Butane from the cylinder was used in a camping stove. If there was a large fall in the air temperature around the cylinder, what effect would this have on the flame of the camping stove?

.....
.....

1 mark

Maximum 6 marks

Question 4:

A pen cap floats in a plastic lemonade bottle three-quarters full of water. If you squeeze the bottle the pen cap sinks to the bottom. If you then let go of the bottle, the pen cap floats to the surface.

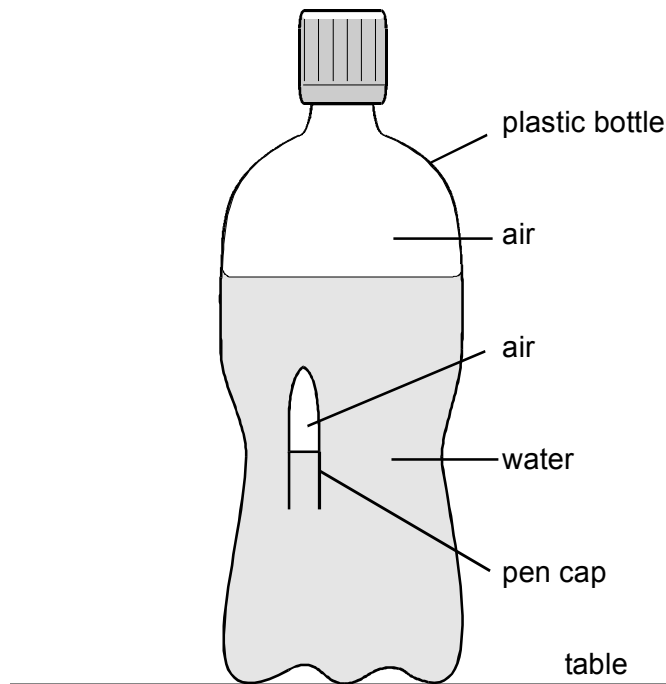

-

(a) When the bottle is squeezed what, if anything, happens to:

(i) the distance between the air molecules inside the bottle?

.....

1 mark

(ii) the distance between the water molecules inside the bottle?

.....

1 mark

(iii) the pressure of the air trapped inside the pen cap?

.....

1 mark

(iv) the volume of the air trapped inside the pen cap?

.....

1 mark

(b) Explain why the pen cap sinks when you squeeze the bottle.

.....
.....
.....
.....

2 marks

Maximum 6 marks

Question 5:

Tom tries on four types of footwear in a sports shop.



ski boot



trainer



ice skate



walking boot

(a) (i) When Tom tries on the footwear, which one sinks into the carpet the most?

.....

1 mark

(ii) When Tom tries on the footwear, what is the same for each type of footwear? Tick the correct box.

the area of the footwear

Tom's weight on the footwear

the material of the footwear

the weight of the footwear

1 mark

(b) The drawing below shows a snowshoe.



How do snowshoes help people to walk in deep snow?

.....
.....

1 mark

(c) Choose the correct word from the list to complete the sentence below.

air resistance friction gravity magnetism

When Tom is ice skating the force of

between the skate and the ice is less than when he is walking on a carpet.

1 mark

Maximum 4 marks